

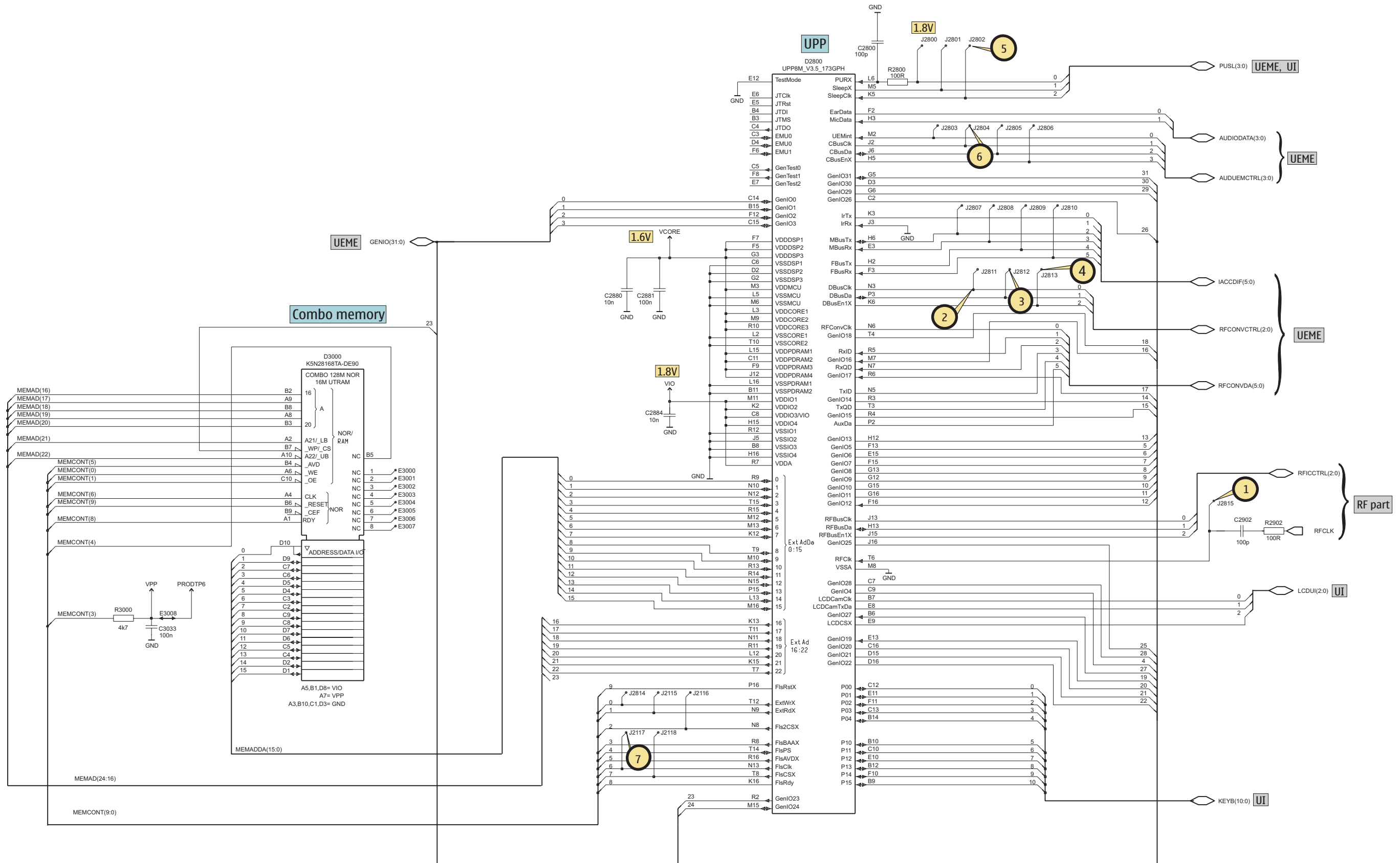





UPP, Combo Memory



Camera

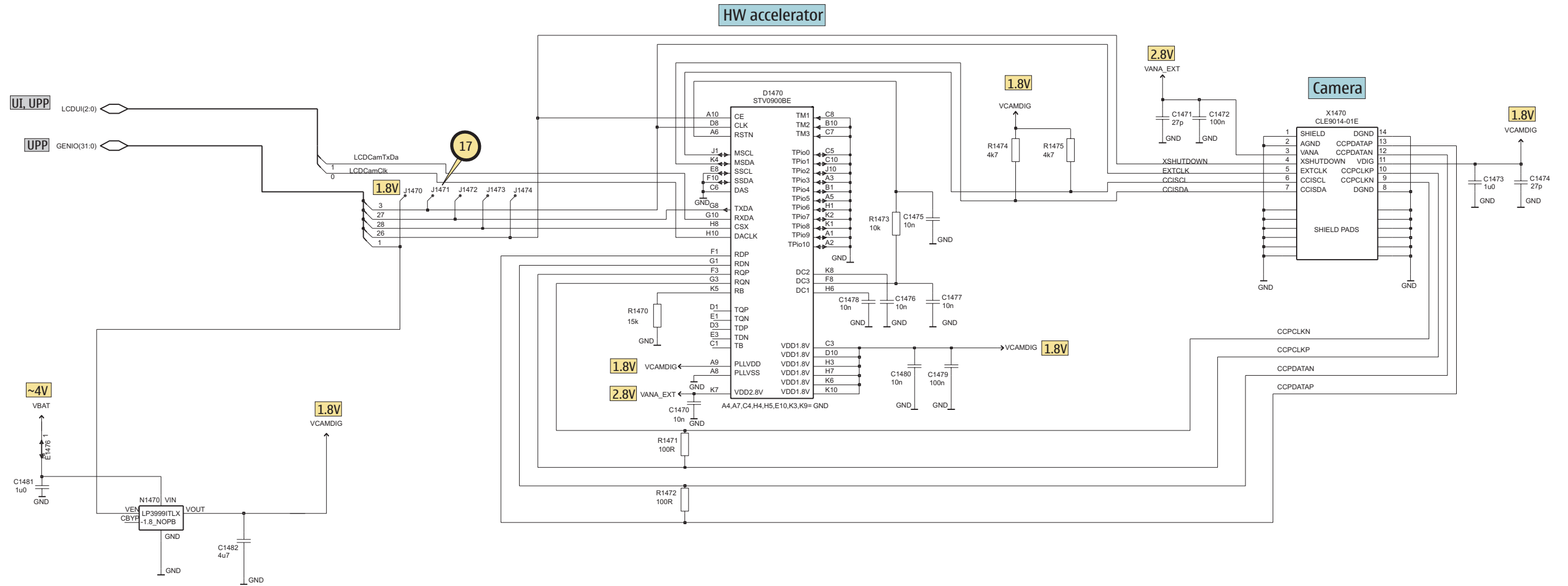

UI, Vibra, Keyboard

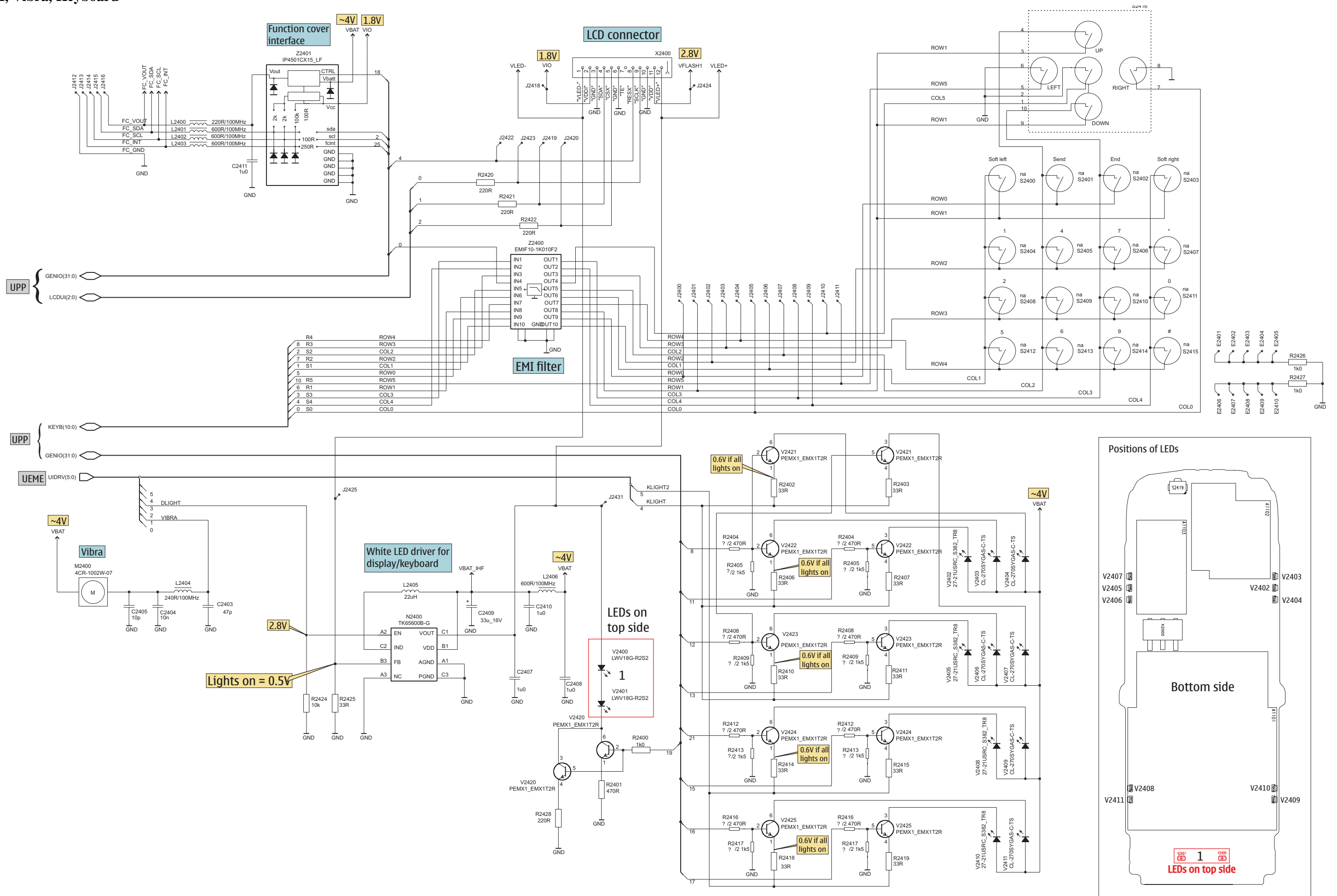

RF Part

VANT_2	VANT_3	VANT_1	RX 1	RX 2	RX 3	TX 1	TX 2
VC1	VC2	VC3	GSM900	GSM1800	GSM1900	GSM900	GSM1800/1900
[Volt]	[Volt]	[Volt]	RX	RX	RX	TX	TX
0	0	0	X				
0	0	0		X			
0	2.6	2.6				X	
0	2.6	0			X		
2.6	2.6	0					X

Band	Channel	RX	VCO/RX	VC/RX	TX	VCO/TX	VC/TX
EGSM 900	37	942,4MHz	3769,6MHz	~2,73V	897,4MHz	3589,6MHz	~1,99V
GSM 1800	700	1842,8MHz	3685,6MHz	~2,39V	1747,8MHz	3495,6MHz	~1,60V
GSM 1900	661	1960,0MHz	3920,0MHz	~3,31V	1880,0MHz	3760,0MHz	~2,96V

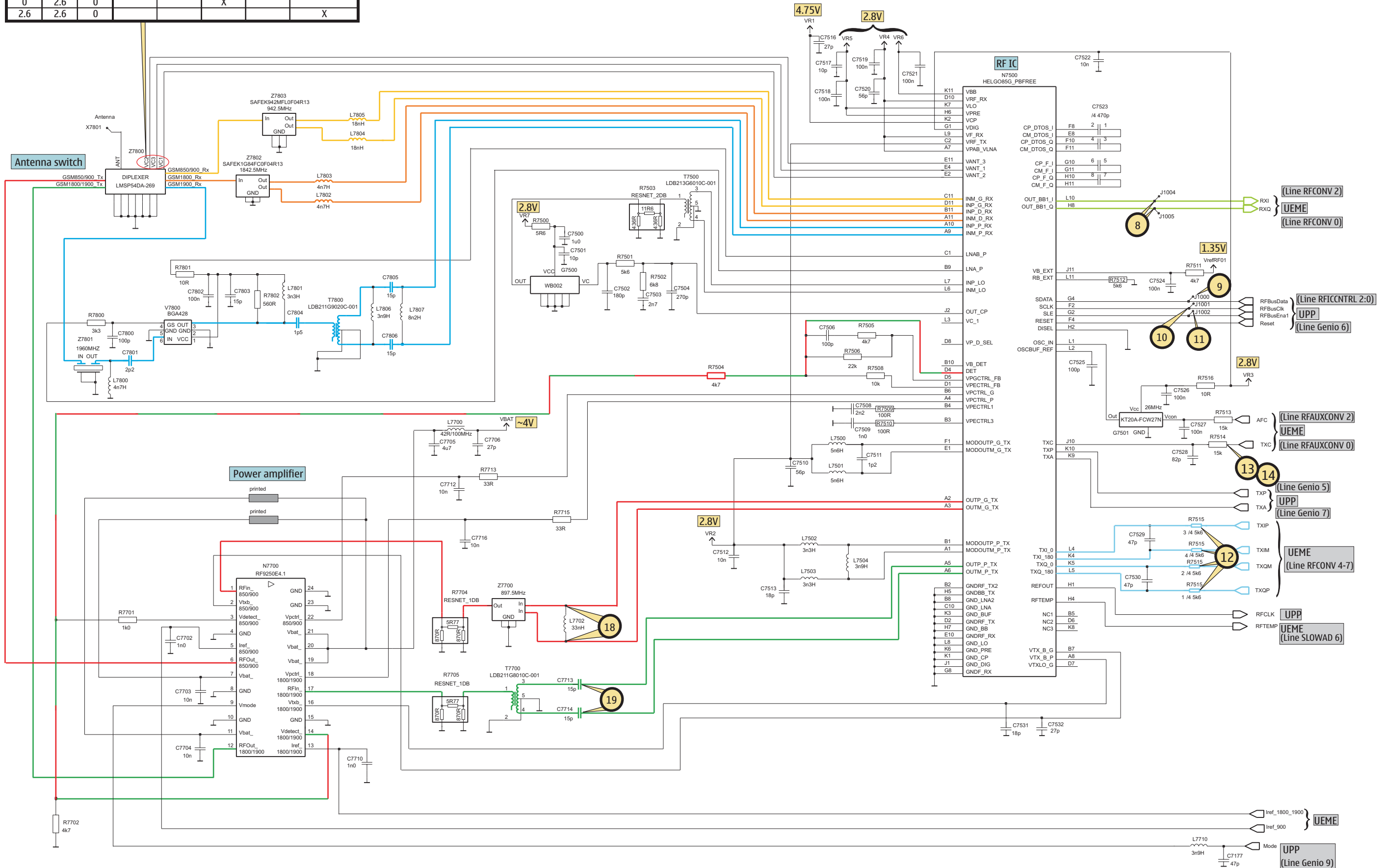

Signal Overview

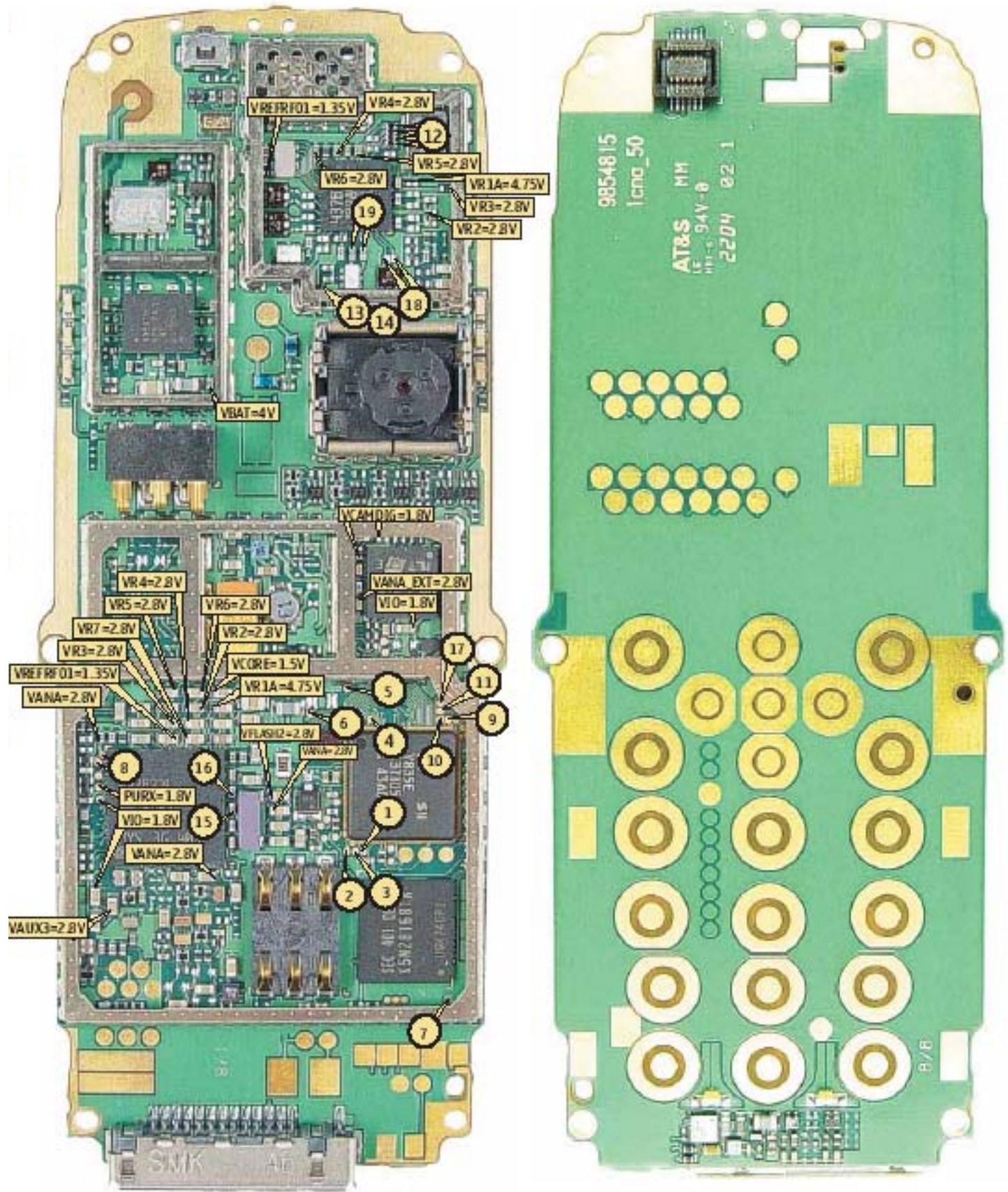
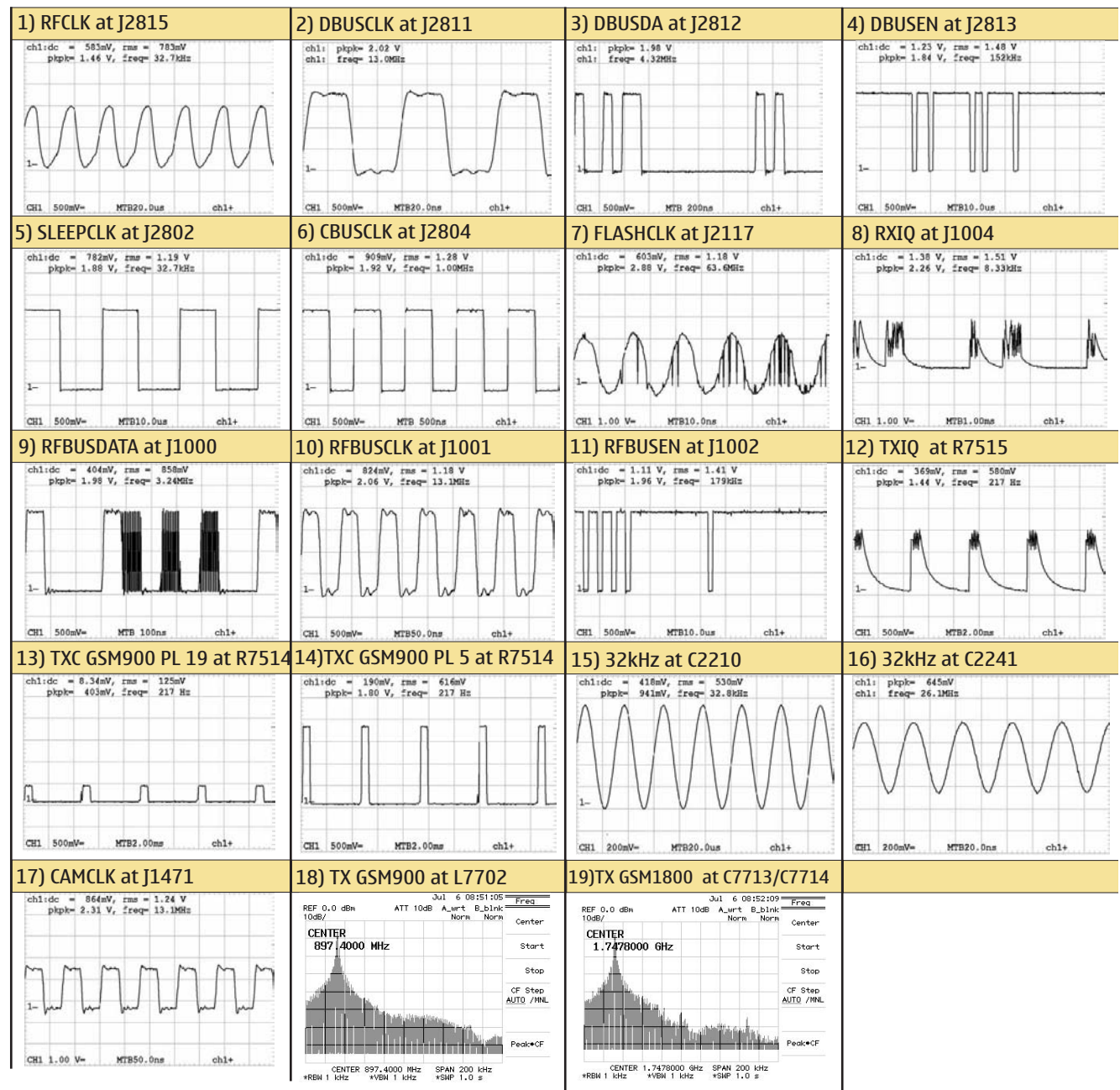



Component Finder

B	C2205	N5	C3033	P7	C7717	F4	J2410	I8	L2405	K5	R2172	P4	R7507	E8	
B2200	O5	C2206	N5	C3180	O8	C7718	F2	J2411	I8	L2406	J4	R2173	Q4	R7508	E8
B2400	B4	C2207	M4	C6156	J3	C7719	F2	J2412	S8	L6156	J3	R2174	P4	R7509	F8
B2401	F4	C2208	P2	C6157	J3	C7720	F4	J2413	S7	L6176	J2	R2175	P3	R7510	F8
B2402	S6	C2209	Q3	C6158	J3	C7721	F4	J2414	S7	L7500	D7	R2176	P3	R7511	D5
C	C2210	O4	C6159	L4	C7722	G3	J2415	S7	L7501	D7	R2200	N5	R7512	C6	
C1470	K6	C2211	O5	C6162	J3	C7800	D4	J2416	S8	L7502	E7	R2201	P3	R7513	C8
C1471	K6	C2212	P2	C6163	L3	C7801	D3	J2418	G8	L7503	E7	R2270	O2	R7514	F6
C1472	K6	C2213	O5	C6164	K4	C7802	D3	J2419	G7	L7504	E7	R2271	N2	R7515	C7
C1473	J6	C2214	O5	C6165	L3	C7803	E4	J2420	H6	L7700	G4	R2272	N2	R7516	D8
C1474	J7	C2215	P4	C6170	J3	C7804	E4	J2421	H6	L7701	G2	R2273	O2	R7517	E8
C1475	J8	C2216	O2	C6173	L2	C7805	E6	J2422	G7	L7702	E7	R2274	P2	R7700	N2
C1476	K6	C2217	O2	C6175	L2	C7806	E6	J2423	G6	L7704	F2	R2400	L6	R7701	G2
C1477	L7	C2218	P4	C6176	K2	C7807	E5	J2424	H7	L7705	F4	R2401	L5	R7702	F4
C1478	K6	C2219	K2	C6178	K2	C7808	D5	J2425	H7	L7710	H2	R2402	J8	R7704	G2
C1479	L8	C2220	M2	C6179	K2	D	J2426	B4	L7800	D3	R2403	I8	R7705	G4	
C1480	K8	C2221	M2	C6180	L3	D1470	K7	J2427	B4	L7801	E4	R2404	I8	R7712	G3
C1481	L8	C2222	M3	C6182	L3	D2200	O3	J2428	I5	L7802	E6	R2405	I8	R7713	G3
C1482	L7	C2223	M3	C6184	P3	D2800	N7	J2429	S6	L7803	E6	R2406	I8	R7715	G3
C1483	L7	C2224	M3	C6185	Q4	D3000	Q7	J2430	S6	L7804	D6	R2407	I8	R7716	G3
C2001	M5	C2225	M2	C7177	G2	F	J2431	H8	L7805	D6	R2408	I7	R7800	D4	
C2002	H2	C2226	M3	C7500	B5	F2000	T5	J2800	N2	L7806	E6	R2409	I7	R7801	E4
C2003	H2	C2227	M4	C7501	B5	G	J2801	N2	L7807	E6	R2410	I7	R7802	E4	
C2004	I2	C2228	N5	C7502	B6	G2400	H5	J2802	M6	M	R2411	I7	S		
C2005	O6	C2229	N4	C7503	B6	G7500	B5	J2803	O6	M2400	S3	R2412	I5	S2419	B4
C2006	T5	C2230	M4	C7504	B6	G7501	C8	J2804	M6	N	R2413	I5	T		
C2007	N4	C2231	M4	C7506	E8	J	J2805	O7	N1470	L8	R2414	I5	T7500	C6	
C2008	U5	C2232	M3	C7507	E8	J1000	M8	J2806	N2	N2150	J5	R2415	I6	T7700	F6
C2009	Q2	C2233	M4	C7508	F8	J1001	M8	J2807	O6	N2400	J5	R2416	I6	T7800	E5
C2010	M6	C2234	M3	C7509	E8	J1002	M8	J2808	O6	N6156	K3	R2417	I6	V	
C2011	R2	C2235	M4	C7510	D8	J1003	M8	J2809	O6	N6158	K3	R2418	I6	V2000	O6
C2012	U5	C2236	M4	C7511	D7	J1004	N8	J2810	O6	N7500	D6	R2419	I6	V2400	T4
C2013	U5	C2237	M4	C7512	E8	J1005	N8	J2811	O6	N7700	F3	R2420	L7	V2401	T6
C2014	T4	C2238	M3	C7513	E8	J1006	M8	J2812	O6	R	R2421	L7	V2402	G9	
C2015	T4	C2239	M5	C7516	D7	J1470	M8	J2813	M7	R1470	K6	R2422	L7	V2403	F9
C2016	T4	C2240	P3	C7517	C6	J1471	M8	J2814	R7	R1471	J7	R2423	B4	V2404	G9
C2017	T4	C2241	O4	C7518	C6	J1472	L7	J2815	O7	R1472	J7	R2424	J5	V2405	G2
C2018	U4	C2270	O2	C7519	C6	J1473	L7	J3100	O6	R1473	K8	R2425	J5	V2406	G2
C2019	U4	C2271	P2	C7520	E6	J1474	J8	J3101	N6	R1474	J6	R2426	H9	V2407	F2
C2020	U4	C2272	N2	C7521	C6	J2000	I2	J3102	O6	R1475	J6	R2427	H2	V2408	P2
C2021	U4	C2273	O4	C7522	D7	J2001	I4	J3103	P6	R1476	L7	R2428	L6	V2409	Q8
C2150	Q4	C2400	P4	C7523	D5	J2002	H4	J3104	P6	R1477	K8	R2700	R4	V2410	P8
C2151	K6	C2401	O4	C7524	D5	J2003	H2	J3105	P6	R1478	L8	R2701	R4	V2411	Q2
C2152	R3	C2402	B4	C7525	D7	J2004	H3	J3106	O6	R2000	T6	R2800	O6	V2420	L5
C2153	J5	C2403	Q3	C7526	C8	J2005	S8	J3107	O6	R2001	O6	R2900	M2	V2421	I8
C2154	Q3	C2404	Q2	C7527	C7	J2006	S7	J3108	N6	R2002	R2	R2901	M2	V2422	I8
C2155	K6	C2405	Q2	C7528	F6	J2007	G6	J3109	N6	R2003	Q2	R2902	O8	V2423	I7
C2156	K6	C2406	C4	C7529	C7	J2008	S3	J3181	O7	R2004	R3	R2903	M2	V2424	I6
C2157	P3	C2407	K5	C7530	C7	J2009	S3	J3182	O8	R2005	R2	R3000	O7	V2425	I6
C2159	Q3	C2408	J4	C7531	E6	J2100	S2	J3183	O8	R2006	T5	R3180	O8	V7800	D4
C2164	P2	C2409	K4	C7532	E6	J2100_P	G5	L	R2007	T5	R6156	K4	X		
C2170	Q4	C2410	J4	C7533	F8	J2101_N	F5	L2000	T5	R2008	T4	R6159	J3	X1470	H7
C2171	Q3	C2411	U6	C7701	G2	J2100	G5	L2001	T4	R2009	T4	R6160	J3	X2000	I3
C2173	P4	C2700	P4	C7702	F2	J2101	F5	L2002	T4	R2010	T4	R6161	L2	X2001	T7
C2175	R3	C2701	R5	C7703	F3	J2115	R7	L2003	T5	R2011	T4	R6163	J3	X2002	T4
C2176	R4	C2702	R6	C7704	F3	J2116	P7	L2004	U5	R2151	C4	R6166	L3	X2060	C4
C2177	G5	C2703	R6	C7705	H3	J2117	R8	L2005	T6	R2152	J5	R6169	K4	X2400	B6
C2178	G5	C2800	O6	C7706	G4	J2118	R7	L2006	K2	R2153	Q3	R6180	L3	X2401	S7
C2179	Q3	C2880	N6	C7707	F2	J2400	I5	L2150	C4	R2154	P3	R6181	L3	X2700	Q5
C2180	G5	C2881	N6	C7708	G3	J2401	I5	L2153	Q3	R2155	J6	R6182	P3	Z	
C2181	P3	C2882	N8	C7709	G4	J2402	I6	L2154	G5	R2156	Q3	R6183	P4	Z2400	N6
C2184	R4	C2884	N6	C7710	F4	J2403	I6	L2155	G5	R2158	Q4	R7500	C5	Z2401	T6
C2187	Q4	C2885	N8	C7711	F2	J2404	I6	L2200	M5	R2159	Q4	R7501	B6	Z7700	F7
C2200	N5	C2900	N2	C7712	G3	J2405	I6	L2400	T6	R2160	Q3	R7502	B6	Z7800	E3
C2201	N4	C2901	M2	C7713	E7	J2406	I7	L2401	T6	R2162	Q4	R7503	C6	Z7801	D3
C2202	P3	C2902	O8	C7714	E6	J2407	I7	L2402	U6	R2163	J6	R7504	E7	Z7802	E5
C2204	O5	C3031	R6	C7716	G3	J2409	I7	L2404	Q2	R2171	Q4	R7506	E7		

